

# SPECIFICATIONS

# CRUISER 4115 & 4120 CRUISER 5115 & 5120

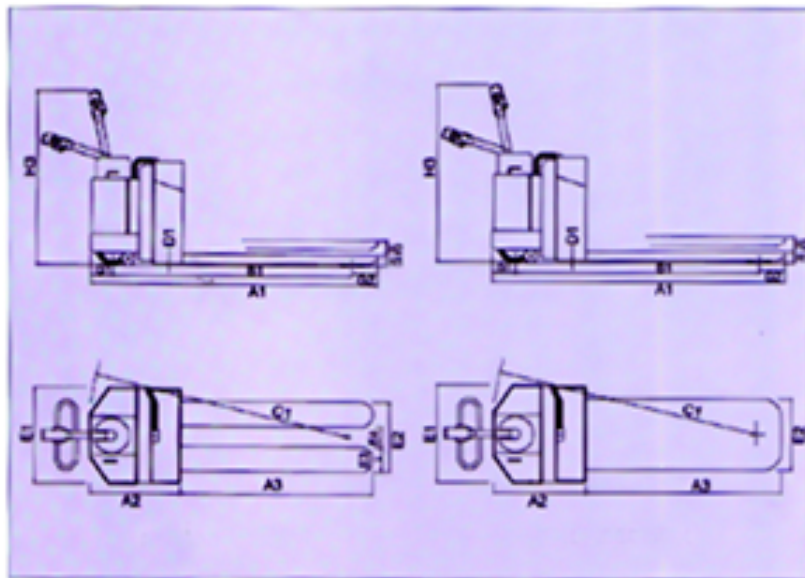

STANDARD DIMENSIONS	PALLET TRUCK CRUISER 4115/4120 mm	STILLAGE TRUCK CRUISER 5115/5120
A1 Overall Length	1711	1711
A2 Power Unit Length	711	711
A3 Fork / Platform Length	1000	1000
B1 Wheel Base (Lowered)	1344	1344
C1 Turning Radius	1511	1511
D1 Under Clearance	15	50
E1 Width of Power Unit	766	766
E2 Width Over Fork / Platform	560	560
E3 Width of Fork	200	-
E4 Width between Forks	160	-
G1 Rear Overhang	167	167
G1 Front Overhang (lowered)	200	200
Front Overhang (Raised)	292	292
H1 Height of Fork / Platform	86	160
H2 Height of Lift	115	115
Capacity (distributed evenly)	1500/2000 kg	1500/2000 kg
Battery	24v, 162 AH	24v, 162 AH
H3 Overall Height	1360	1360

All dimensions and performance data given in this leaflet may vary by  $\pm 12\%$  due to manufacturing tolerances. Performance may also be affected by operating conditions, the inclusion of ancillary equipment, and alternative specification variations. The manufacturers reserve the right to alter specifications without notice.

## TRAVEL SPEEDS

Unladen : 5 kmph / laden : 4 kmph

## GRADIENT

Maximum (laden 1:10) - 10%

## LIFT TURNS (CRUISER 4115/5115)

Unladen : 6 secs. approx, Laden : 8 secs. approx.

## LIFT TIMES (CRUISER 4120/5120)

Unladen : 6.5 secs. approx, Laden : 9 secs. approx.

## DRIVE WHEEL (CRUISER 4115/4120 & 5115/5120)

A For Full Chain Transmission Single bonded cushion rubber 254 mm dia / 102 mm wide or Polyurethane 254 mm dia / 70 mm wide.

B For Primary Chain and Secondary Gear Transmission 254 mm dia / 70 mm wide Polyurethane.

## LOAD WHEEL (CRUISER 4115/4120)

Two sets of Twin Steek Wheels in tandem

Size : 83 mm dia x 88 mm Wide

Alternatively Nylon Load Wheels and Polyurethane Wheels Available

(CRUISER 5115/5120)

Two numbers Polyurethane / Nylon / Steel Load Wheels dia 140 mm x 112 mm Wide.

## WHEELS & TYRES (CRUISER 2115/2120)

Drive Wheel : Single bonded cushion rubber/polyurethane 254 mm. dia 102 mm. Wide.

Load Wheels : Two nos. polymer / nylon / steel.

Size 140 mm. dia 112 mm. wide.

## 90° STACKING AISLE

Load Length (mm)	1000	1220	1525
CRUISER 4114 & 5115	1710	1930	2235

The aisle dimensions shown are the minimum required by the truck and its load and an allowance for operating clearance must be added.

## ALTERNATE CONDITIONS

(CRUISER 4115 / 4120 & 5115 / 5120)

FORK SIZE MM	OVERALL LENGTH A1	WHEEL BASE B1	TURNING RADIUS C1
560 X 1000	1711	1344	1511
560 X 1220	1931	1564	1731
560 X 1525	2236	1869	2036
690 X 1000	1711	1344	1511
690 X 1220	1931	1564	1731
690 X 1525	2236	1869	2036

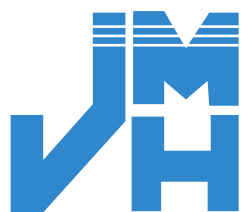

# JALDOOT

Material Handling Pvt. Ltd.

J - 83 MIDC, Bhosari, Pune - 411 0026

Tel. : 020 - 712 0412, 712 4635

Fax : 020 - 712 1384

Email : jaldoot@vsnl.com

Website : www.jaldoot.com